

DETACHED RESIDENTIAL ACCESSORY BUILDINGS

A photograph of a wooden detached accessory building. The building has a double door with metal hinges and a latch. On the right side of the building, three tools are hanging on a metal rack: a yellow-handled shovel, a silver-handled shovel, and a red-handled tool. The building is surrounded by green ferns and other foliage. The background shows trees and a clear sky.

A GUIDE TO
DETACHED ACCESSORY
BUILDINGS AND OBTAINING PERMITS.

Note:

Detached accessory buildings, such as garages and storage sheds, vary in size and area. It is beyond the scope of this booklet to deal with every possible situation. The requirements and construction guidelines that follow are provided to assist you in designing and constructing a detached garage or storage shed which will comply with the regulations. If the nature of your project is different than that contained in this booklet and you are not familiar with the regulations which may be applicable, it is recommended that you contact someone who is knowledgeable in this area.

The Sarnia Building By-law is primarily an administrative document that adopts the Ontario Building Code and related standards to provide construction requirements. Throughout this booklet the information provided is based on the minimum standards set out in the Ontario Building Code and City Zoning By-law. Every effort has been made to ensure the accuracy of information contained in this booklet. However, in the event of a discrepancy between this booklet and the governing Act, Regulation or By-law, the Act, Regulation or By-law will take precedence.

We strongly encourage applicants to discuss their specific projects with staff in the Planning and Building Department of the City prior to commencement.

Frequently Asked Questions

Is a building permit required to build a detached garage, storage shed or carport?

Any accessory building over 10m² (108ft²) in size will require a building permit.

What information do I need to obtain a building permit?

1. Application - You are to complete a building permit application in full.

2. Site Plan - You will need to attach two (2) site plans consisting of the property measurements, dwelling and any other building locations and measurements. Indicate front, side, and rear setbacks from the lot lines. Location and size of the proposed garage or shed must also be included. See example below.

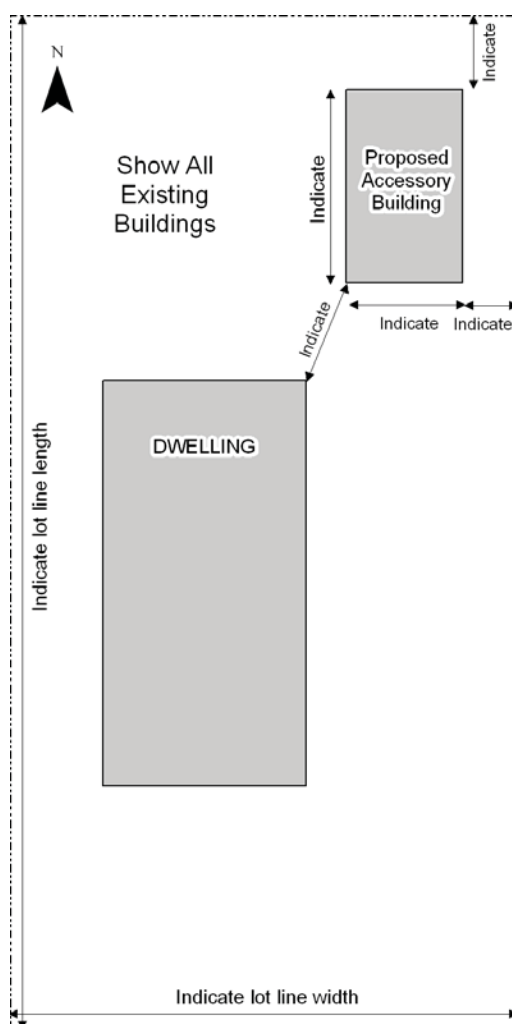

Can I assume that the City sidewalk, edge of pavement, or neighbour's fence is the property line?

No. To accurately determine the location of your property line, please speak to a Land Surveyor.

3. Construction Plans:

Garage/Shed not more than 50m² (538 sq. ft.)

Smaller buildings do not normally require submission of construction plans, however, in some instances, plan and designs may be required from a professional engineer. Review this document for such situations or call the Building Department directly.

Garage/Shed more than 50m² (538 sq. ft.)

Larger buildings require submission of a floor plan, section and elevations. These plans must be clear and to scale. There must also be sufficient detail to allow building staff to determine compliance to the Ontario Building Code. If you are having someone else provide the plans they must be registered with the Ministry of Housing (MMAH) as a registered designer.

What is required to be shown on the floor plan?

- Size of garage/shed with dimensions
- Location and sizes of windows, doors, etc.
- Size of beams/lintels in wall openings, if required
- Direction of roof trusses

What details are required on the section drawing?

- Type and thickness of materials in the roof, walls and floor construction assembly
- Dimension of height of wall, pitch of roof and size of overhang

What information should be indicated on the elevation drawing?

- Type of finish siding material
- Window and door location
- Indicate roof slope and overhang (OH)
- Total building height
- Foundation line
- Grade line

Zoning

How far away from the property line should my building be?

PLEASE NOTE: The following setbacks are only generalized guidelines. Please speak with the Planning Department to confirm setback requirements for your specific property.

Any accessory building needs a minimum clearance of 1m from a dwelling located on the same lot, measured eave to eave.

In most cases, to build in a rear yard, a detached accessory building needs to have a minimum building setback of 0.6m from the rear and side property lines (Figure 1).

Figure 1:

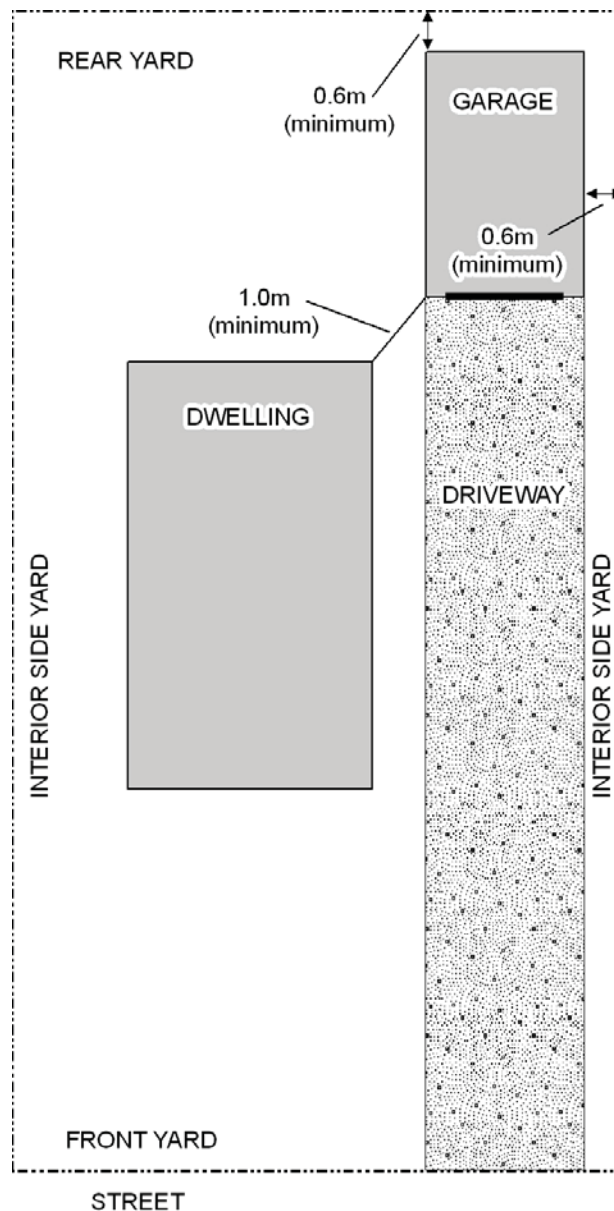

The setbacks for detached accessory buildings on corner lots vary—depending on the location of the corner lot where they are built, and the configuration of the abutting lots.

For corner lots—it is recommended that you contact the Planning and Building Department to discuss your building proposal.

As shown in Figure 2, where the side lot line of a corner lot (shown as “A”) is the continuation of the front lot line of an adjoining lot (shown as “B”) - a detached accessory building on the corner lot shall be set back the same depth as is required for the front yard of the adjoining lot (shown as “C”). The building setback to the side lot line of the adjoining lot shall be at least 1.2m (shown as “D”).

Figure 2:

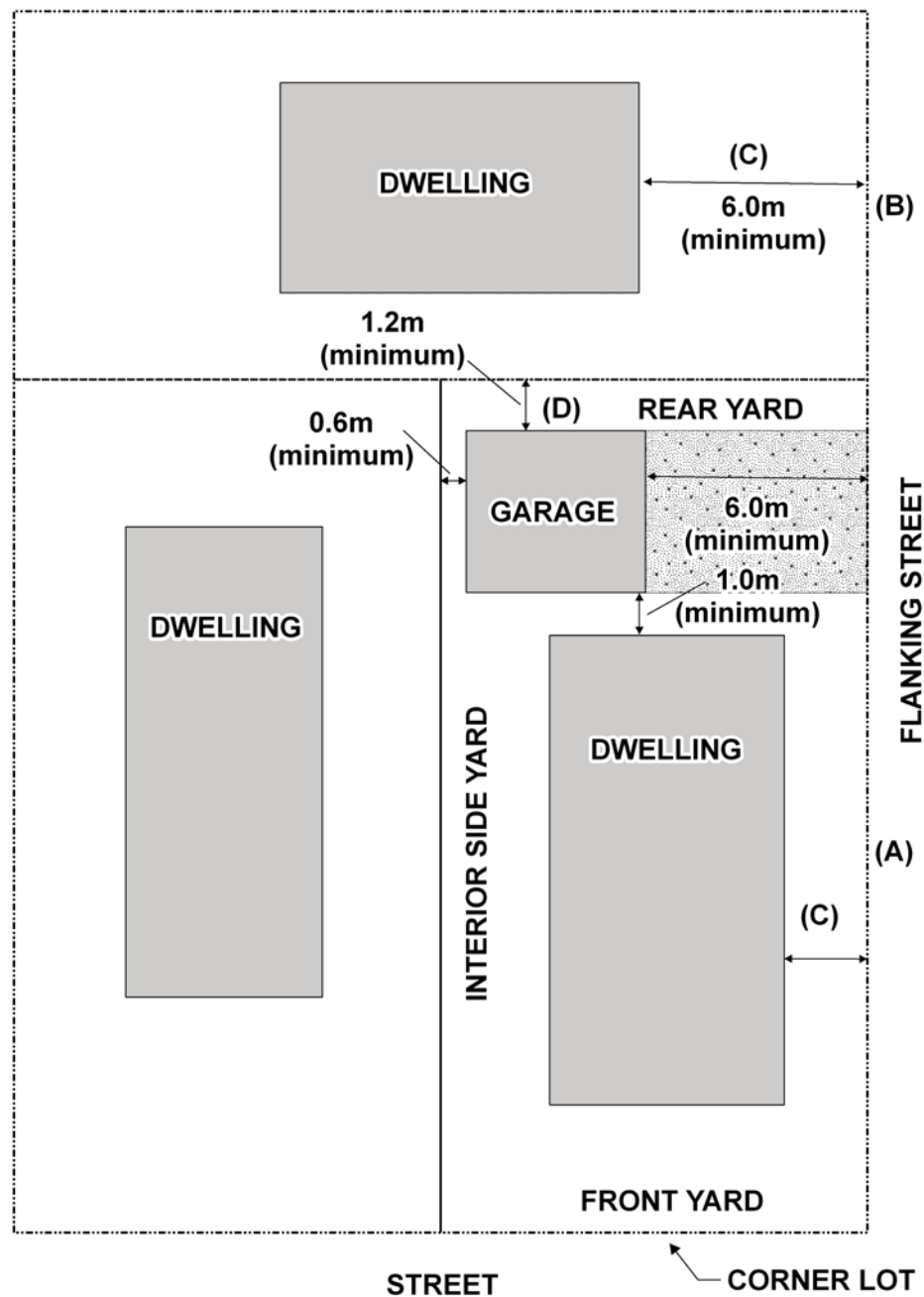

As shown in Figure 3, in any rear yard, a freestanding garage or other accessory building shall have a minimum building setback of 0.6m. No accessory building shall be closer than 3m to a flanking street. If a garage or carport has a vehicular entrance that faces the street, a minimum setback of 6m is required.

Figure 3:

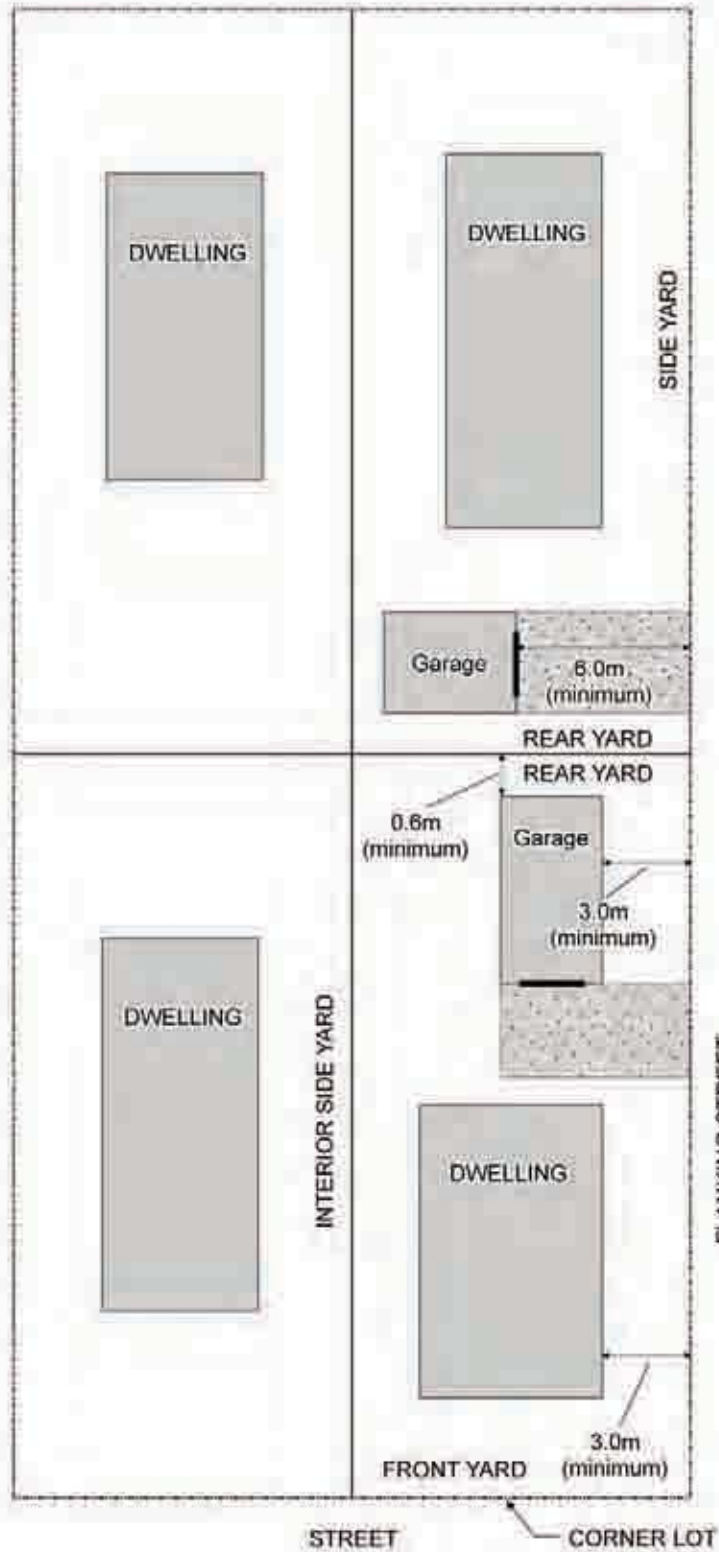

Do these setbacks include the overhang?

The setback does not include an eave projection which needs to have a minimum setback of 0.3m from the property line.

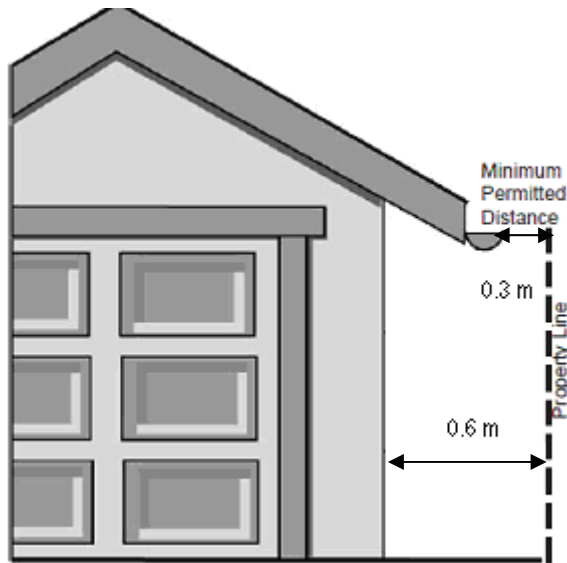

What is the maximum height allowable?

The maximum height for an accessory building with a peaked roof is 1 storey which is not more than 5m from average grade. However, if the accessory building has a flat roof, the maximum building height can be 1 storey and not more than 3.5m from average grade.

How large of a garage can I build?

In any Residential Zone, the maximum combined lot coverage for all accessory buildings is 10% of the lot area or 65m², whichever is less.

If I cannot meet these requirements, what are my alternatives?

City Council has appointed a Committee of Adjustment to consider applications for relief from the By-law requirements. To apply for a minor variance, please contact the Planning Department at City Hall.

Foundations

What type of foundation is required for a one-storey wood frame detached garage?

For a detached garage having a building area of less than 50m² (538sq.ft.) it is recommended that a concrete slab with a thickness of not less than 100mm (4in.) be used as shown in Figure 4a.

For a building area of 50 to 65m² (538 to 700sq.ft.) inclusive, it is recommended that a thickened edge concrete slab be used as shown in Figure 4b or 4c.

For foundations other than those shown in Figures 4a and 4b, or if the building area is greater than 65m² (700sq.ft.), or if brick or masonry veneer is to be installed, the foundation must be designed by a professional engineer registered in the Province of Ontario.

Foundation Plans for 1-Storey Detached Garages

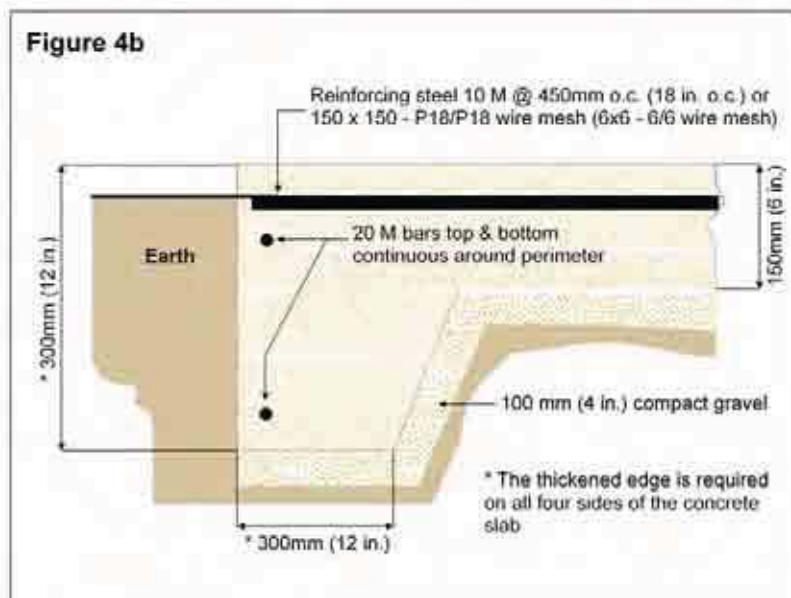
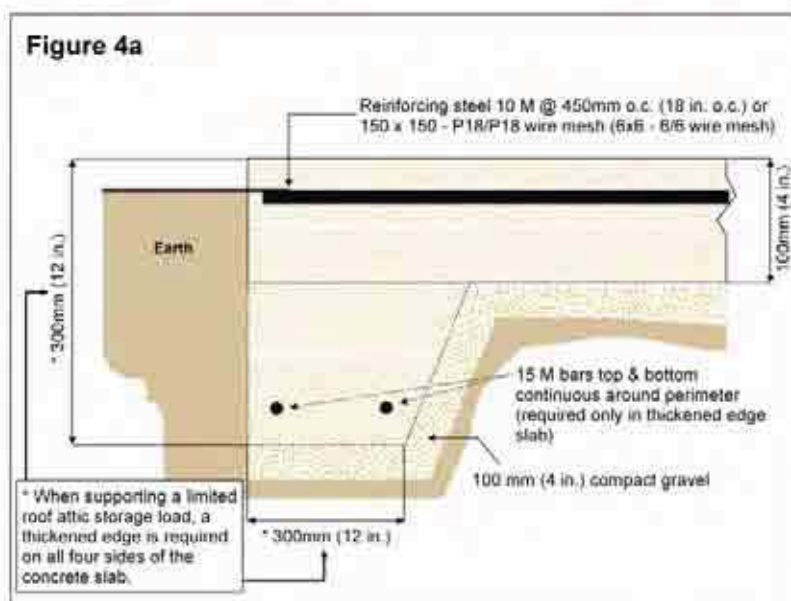

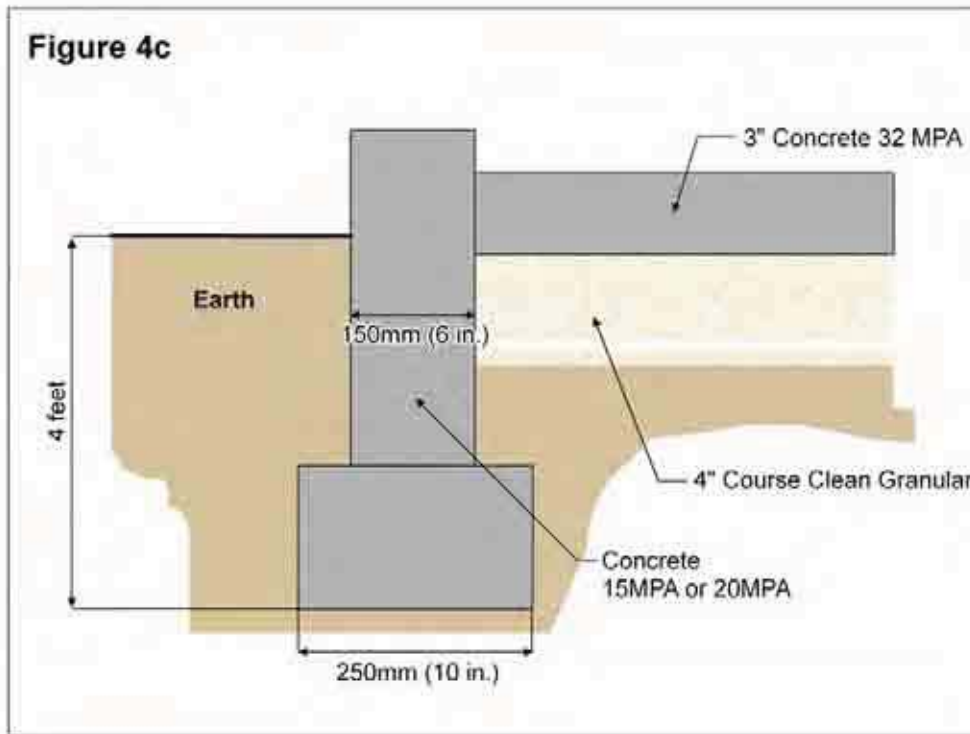

What if I add on to my existing garage?

For a garage, shed or carport addition to an existing structure, the entire foundation, both the existing and the addition, must be made to comply with the foundation requirements shown in Figures 4a, 4b and/or 4c or alternatively the foundation must be designed by a professional engineer.

Can I vary from the foundation slab details shown in this pamphlet?

The details and standards in the pamphlet are considered non-engineered details and are based on past "good construction practice". Variations from these design standards are ONLY permitted where the design is by a professional engineer. Some variations that will require an engineer are:

1. Wood mudsill foundation and anchorage details to prevent uplift due to wind.
2. Foundation slab that includes a curb of more than 150mm (6in.) or retaining wall to hold back the earth where the lot is not level.
3. Foundation slab that is greater than 70m² (753sq.ft.)
4. Foundation slab that supports brick or masonry construction.

What type of concrete do I require for my foundation slab?

Concrete used for all detached garage or shed foundation slabs must have a minimum compressive strength of 32 MPa (4600 psi) after 28 days and must have air entrainment of 5 to 8 per cent.

Framing

What types of framing methods are acceptable?

The framing details described in this pamphlet are based on a 1-storey wood-framed structure that do not include any additional superimposed loads and further design consideration may be required to address these additional superimposed loads. Framing methods must be in accordance with good engineering practice. A detailed discussion of this aspect of construction is beyond the scope of this publication. However, some common framing details are indicated on the following pages. Refer to Figures 5,6 & 7, and Tables 1 & 2.

For more detailed information refer to the book **Canadian Wood Frame House Construction** available to purchase from Canada Mortgage and Housing Corporation (CMHC), 4th floor, 10 Fort St., telephone 983-5600. This publication is an excellent guide to good framing methods and construction techniques. It also includes information for wall and roof coverings, etc.

Where the structure will not be a standard wood frame structure, such as post and beam, concrete block, brick (including brick veneer) or metal framing or where the framing members exceed that prescribed in this pamphlet, the design must be by a professional engineer and drawings must be submitted under the seal and signature of a professional engineer.

FIGURE 5 – Wall Framing and Lintel Detail

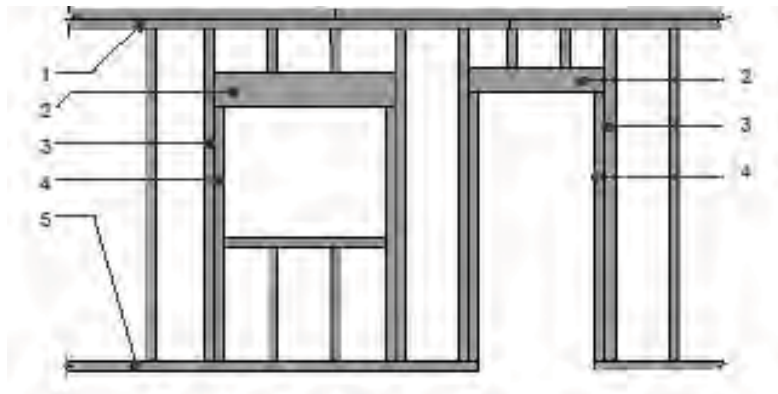

Notes to FIGURE 5:

1. **DOUBLE TOP PLATE:** Joints must be staggered at least one stud spacing. Joints are to be lapped or suitably tied at corners or intersecting walls.
2. **LINTEL:** Refer to Table 1 to determine the size of lintel required for the opening width you select.
3. **THROUGH STUD:** Refer to Table 2 to determine the maximum spacing and maximum unsupported height of studs.
4. **CRIPPLE STUD:** The Building Code requires these studs to be a single full length piece of lumber extending from the underside of the lintel to the bottom plate. Two cripples are required on both sides of opening when opening is greater than 3m (9 ft. 10 in.)
5. **SINGLE BOTTOM PLATE:** To prevent uplift, this bottom plate should be firmly anchored down at each side of door openings, at each end of each wall, and at intervals not exceeding 2.4m (7 ft. 10 in.) Bottom plate is to be pressure treated and or separated from concrete by polymembran to resist decay.

Figure 6 – Exterior Corner Detail

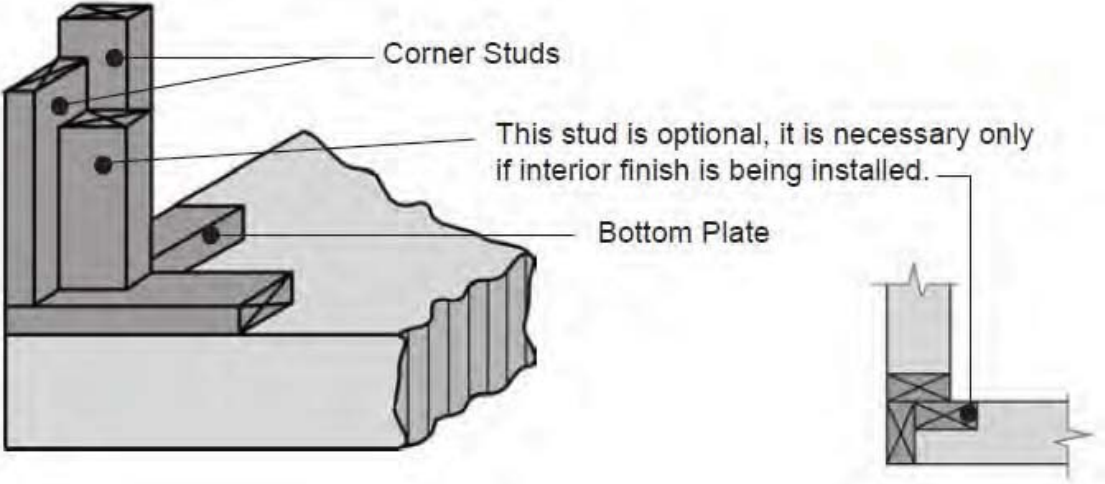

Figure 7 – Exterior Wall Framing at Gable End Detail

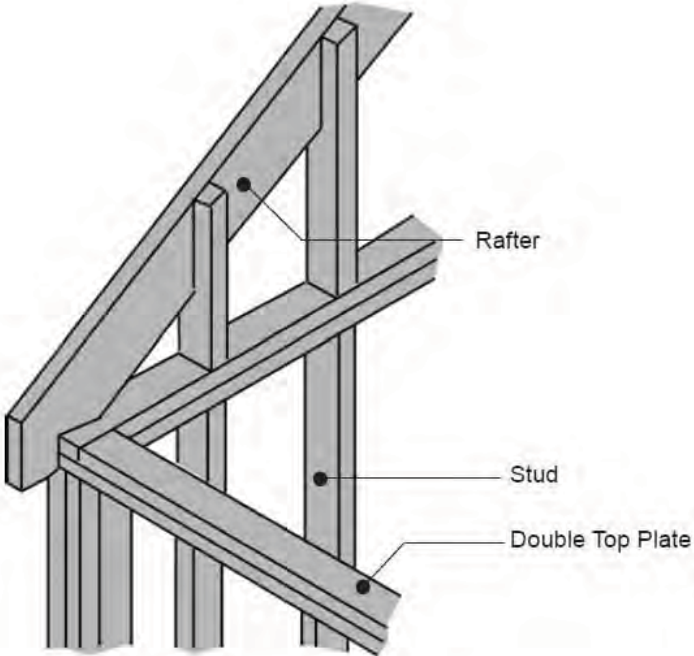

Table 1

Wood Lintel Spans for Windows and Man Doors	
Size of Lintels	Maximum Allowable Spans
2 – 38 x 89 mm (2 - 2 x 4)	1.11 (3'- 8")
2 – 38 x 140 mm (2 - 2 x 6)	1.66 (5'- 5")
2 – 38 x 184 mm (2 - 2 x 8)	2.02 (6' – 7")

Notes to Table 1:

1. This table is for use with Spruce-Pine-Fir lumber grades 1 & 2.
2. Built-up lintels must be constructed of full length members. No splicing of members is permitted between supports.

Table 2

Size and Spacing of Studs				
Type of Wall	Supported Loads (including dead loads)	Minimum Stud Size	Maximum Stud Spacing	Maximum Up-supported Height
Exterior	Roof with or without attic storage	38 x 140 mm (2 x 6)	400 mm (16 in.)	5 m (16 ft. 4 in.)
		38 x 89 mm (2 x 4)	600 mm (24 in.)	3.0 m (9 ft. 10 in.)

Notes to Table 2:

This table is for use with all Spruce, Pine, Fir Lumber Grade 1 and 2 and minimum grades of standard, stud and No. 2.

Solid Bridging to be provided at 1200mm O.C (3"-11") between studs.

Overhead Door Lintels

What size of lintel is required for the overhead door?

The size of lintel required depends entirely upon the load which it must support which, in this case, is determined by the style of roof. See Tables 3 & 4.

How are the tables used in determining the required overhead door lintel size?

If the roof style selected is Gable #1 as shown in Figure 8, then Table 3 is used to determine the lintel size. This table is used where the door opening DOES NOT SUPPORT the roof, i.e. where the roof framing elements such as trusses or rafters run parallel to the door opening.

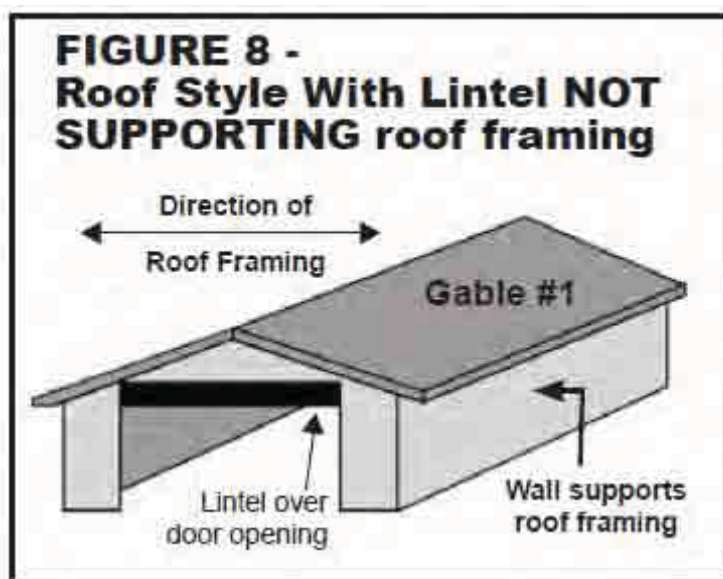

Table 3

Wood Lintels – NOT SUPPORTING Roof Loads	
Maximum Door Opening Width	Lintel – Gable Roof Only (Door in Gable End)
4.61 (15' – 1")	2 – 38 x 184 mm (2 -2 x 8)
5.76 (18' – 10")	2 – 38 x 235 mm (2 -2 x 10)
6.67 (21" – 10")	2 – 38 x 286 mm (3 -2 x 12)

Notes to Table 3:

1. This table is for use with Spruce-Pine-Fir lumber grades 1 & 2.
2. Built-up lintels must be constructed of full length members. No splicing of members is permitted between supports.

If the roof type selected is as shown in Figure 9, i.e. Gable #2, Hip, Mono, or Flat, then Table 4 is used to determine the lintel size. This table is used where the lintel over the door opening SUPPORTS the roof, i.e. where the roof framing elements such as trusses or rafters run perpendicular to the door opening.

To select a size of wood lintel simply match the door opening size with the appropriate supported length in Table 4 to find the minimum lintel size.

FIGURE 9 - Roof Styles With Lintel SUPPORTING Roof framing.

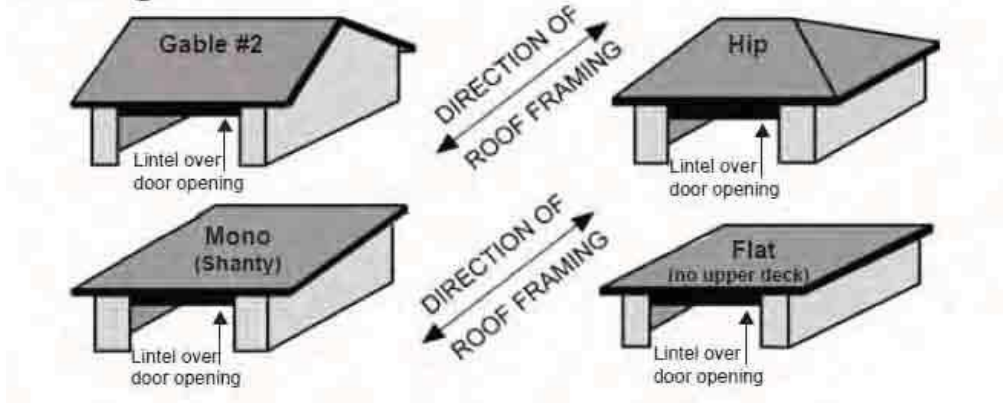

Table 4

Wood Lintels – SUPPORTING Roof Loads				
	Supported Length			
Width of Opening (Lintel Span)	2.44 m (8 ft.) X 1.25	3.66 m (12 ft.) X 1.10	4.27 m (14 ft.) X 1.05	4.88 m (16 ft.)
2.44 m (8 ft.)	3 – 38 x 184 mm (3 – 2 x 8)	3 – 38 x 184 mm (3 – 2 x 8)	3 – 38 x 184 mm (3 – 2 x 8)	3 – 38 x 184 mm (3 – 2 x 8)
2.74 m (9 ft.)	3 – 38 x 184 mm (3 – 2 x 8)	3 – 38 x 235 mm (3 – 2 x 10)	3 – 38 x 235 mm (3 – 2 x 10)	3 – 38 x 235 mm (3 – 2 x 10)
3.05 m (10 ft.)	3 – 38 x 235 mm (3 – 2 x 8)	3 – 38 x 235 mm (3 – 2 x 10)	3 – 38 x 235 mm (3 – 2 x 10)	3 – 38 x 286mm (3 – 2 x 12)
3.66 m (12 ft.)	3 – 38 x 235 mm (3 – 2 x 10)	3 – 38 x 286 mm (3 – 2 x 12)	3 – 38 x 286 mm (3 – 2 x 12)	4 – 38 x 286 mm (4 – 2 x 12)
4.27 m (14 ft.)	3 – 38 x 286 mm (3 – 2 x 12)	4 – 38 x 286 mm (4 – 2 x 12)	130 x 304 Glue Laminated Timber	130 x 304 Glue Laminated Timber
4.88 m (16 ft.)	4 – 38 x 286 mm (4 – 2 x 12)	130 x 304 Glue Laminated Timber	130 x 304 Glue Laminated Timber	80 x 380 Glue Laminated Timber
5.48 m (18 ft.)	130 x 304 Glue Laminated Timber	130 x 342 Glue Laminated Timber	130 x 380 Glue Laminated Timber	130 x 380 Glue Laminated Timber
6.09 m (20 ft.)	130 x 342 Glue Laminated Timber	80 x 456 Glue Laminated Timber	80 x 532 Glue Laminated Timber	80 x 532 Glue Laminated Timber

Notes to TABLE 4:

1. *The lintels in this table are Spruce-Pine-Fir lumber grades 1 & 2.*
2. *Built-up lintels must be constructed of full length members. No splicing of members is permitted between supports.*
3. *Supported length means half the span of trusses, roof joists, or rafters supported by the lintel plus the length of the overhang beyond the lintel (see Figure 10).*
4. *If the supported length is between the sizes shown, use the column with the greater depth. For garages or storage sheds with a door width or supported length greater than shown on the tables, consult a Professional Engineer.*
5. *The spans shown in the table are the clear spans between the load bearing supports at each end of the lintel. To find the total length of lintel needed, add the two bearing lengths of the support to the clear span.*
6. *The minimum bearing length of the support at each end of the lintel must be 89 mm (3 1/2") where spans are greater than 12' ; Where spans are less than 12', the minimum bearing length of the support at each end of the lintel must be 76 mm (3").*
7. *Lintel sizes smaller than those shown on these tables may be used provided the lintel has been designed by a Professional Engineer and the lintel design and calculations are submitted and accepted.*
8. *The above noted lintels are not designed to carry masonry or floors above the overhead door. For these types of applications consult a Professional Engineer.*
9. *Glue Laminated Timber to conform to CAN/CSA-0122-M and CAN/CSA-0177-M and 20fE stress grade.*

LINTEL SIZE SELECTION FOR AN OVERHEAD DOOR

Example: In order to select the correct size of lintel in cases where it is supporting the roof, three pieces of information are needed: the size of the garage, the width of the overhead door opening, and the size of the roof overhang. As an example, assume a 7.32m x 7.32m (24ft x 24ft) garage with a 2.74m (9ft.) overhead door opening and a 600mm (2ft.) overhang.

Refer to Table 4.

Begin by selecting the row for a 2.74m (9ft.) overhead door opening. Next, knowing that the supported length will be half the distance of the roof span plus the overhang (see FIGURE 10), we divide the 7.32m (24ft.) roof span distance by 2 and add the 600mm (2ft.) roof overhang to get the total supported length of 4.27m (14ft.).

Now looking along the table to column 5 where the supported length is 4.27m (14ft.), we see that the proper size of lintel would be 3 - 38 x 235mm (3 - 2 x 10).

FIGURE 10 - Supported Length of Wood Lintel.

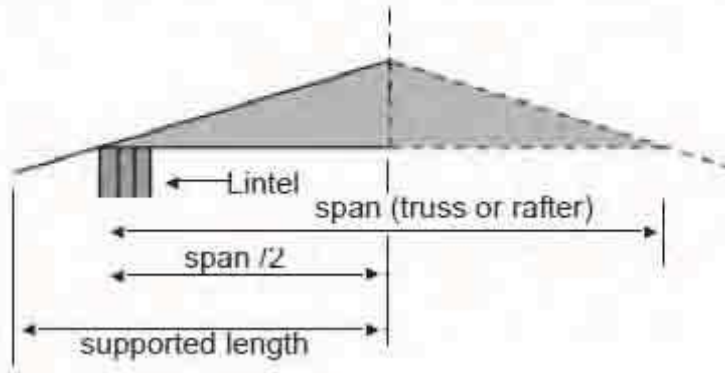

Rafters and Trusses

What roof framing choices are there?

In wood framing, there are basically three methods for framing roofs.

They are:

1) Framing the roof with pre-manufactured trusses.

There are several truss manufacturers and suppliers listed in the Yellow Pages under both LUMBER-RETAIL and TRUSSES. These firms can provide detailed information regarding the proper installation of their products.

Note: When using trusses or rafters at 600mm (24in.) spacings with panel-type roof sheathing of less than 12.7mm (1/2in.) thickness, support must be provided to all edges of each roof sheathing panel including those that meet at the ridge. This can be accomplished with the use of 'H' clips as shown in FIGURE 11 and/or solid blocking.

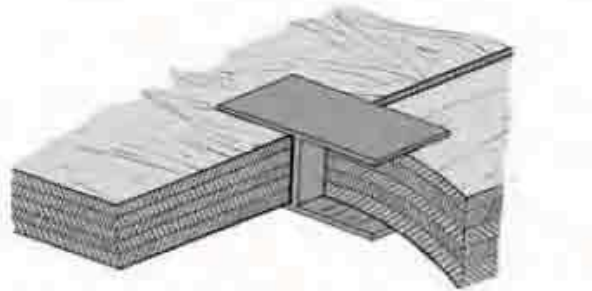

FIGURE 11 - 'H' Clip Detail

2) Framing the roof with individual pieces of lumber (2x4s, 2x6s etc.).

This is commonly known as stick framing. Figure 12 shows a typical cross section of a gable roof and Table 5 indicates maximum rafter spans for various species and sizes of rafters. Note that Figure 12 makes use of collar ties as a means of reducing a full rafter span into two smaller spans. *Collar ties can only be used in this fashion when the roof slope is 1 in 3 or greater.*

If you are framing a roof containing hip or valley rafters, the hip and/or valley rafters must be not less than 50mm (2in.) greater in depth than the common rafters and not less than 38mm (1 1/2in.) in thickness.

FIGURE 12 - Roof Rafter and Collar Ties for Gable Roof.

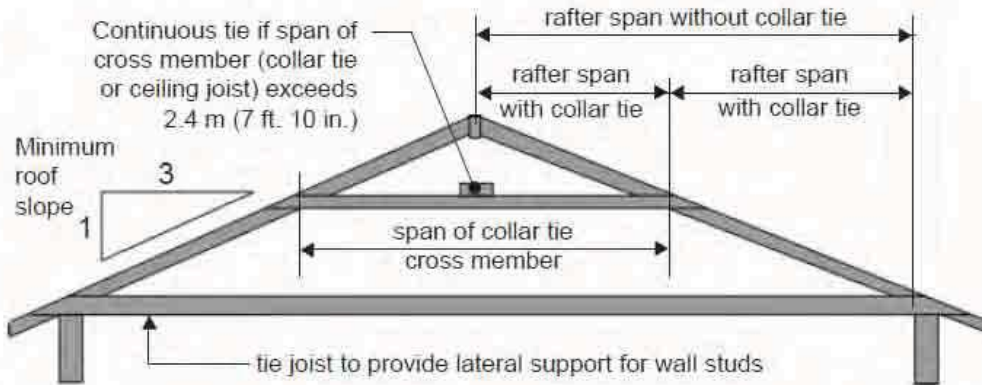

Table 5

Roof Rafter Spans – Rafter NOT SUPPORTING Ceiling									
Commercial Designation	Grade	Member Size (in.)	Rafter Spacing			Member Size (mm)	Rafter Spacing		
			12 in.	16 in.	24 in.		300 mm	400 mm	600 mm
			Ft.- in.	Ft. – in.	Ft. – in.		m	m	m
Spruce – Pine – Fir	No. 1	2 x 4	8 – 11	8 – 1	7 – 1	38 x 89	2.72	2.47	2.16
	And	2 x 6	14 – 0	12 – 9	11 – 1	38 x 140	4.28	3.89	3.40
	No. 2	2 x 8	18 – 5	16 – 9	14 – 5	38 x 184	5.62	5.11	4.41
		2 x 10	23 – 6	21 – 4	17 – 8	38 x 235	7.18	6.52	5.39
		2 x 12	28 – 8	25 – 1	20 – 6	38 x 286	8.74	7.66	6.25

Note to Table 5:

This table applies to roofs with a slope of 1 in 3 or greater. Roof slopes of less than 1 in 3 are subject to different loading conditions, e.g. adequate ridge support must be provided.

ROOF RAFTER SIZE SELECTION

Example: In order to select the correct rafter size for a 6.72m x 6.72m (22ft x 22ft) detached garage or storage shed with a gable roof having a slope of 1 in 3 or greater, and with spruce rafters (without collar ties) spaced 600mm (24in.) apart, we will proceed as follows.

First, we must know the horizontal distance from the wall to the peak of the roof. In this example the distance is 6.72m (22ft.) divided by 2 or 3.36 m (11ft), and is called the rafter span.

Next, keeping in mind that 3.36m (11ft.) is the required rafter span distance, we look to Table 5 in the Spruce - Pine - Fir section for a 600mm (24in.) rafter spacing. We are looking here for a span distance that equals or exceeds 3.36m (11ft.). We find in the table a span that meets our requirements and it has a figure of 3.40m (11ft. 1in.). We now look across to find the member size that is necessary to obtain this span. It is a 38 x 140mm (2 x 6in.) rafter. This rafter size is the minimum size of rafter required for the span of 3.36m (11ft.) for this particular gable style roof.

If collar ties are permitted and are used, the required span would be less than 3.36m (11ft.) and a smaller member size could be looked up in the table.

3) Framing the roof with “home made” trusses.

This is not a recommended design. The truss must be designed by a Professional Engineer registered in the Province of Ontario.

Note: *The use of gang nailers (metal plates) in manufacturing “home made” trusses is not permitted unless extensive engineering involvement and testing is carried out and the supporting documentation is submitted and found acceptable. These types of fasteners are only intended for use under the design and quality control of a truss manufacturer.*

Truss designs vary depending upon spans, roof slope, etc. Before manufacturing your own trusses, obtain an accepted truss design drawing showing the span, the size of the members, the size and thickness of the plywood gussets, and the nailing patterns. Do not copy truss designs used on other buildings. These designs may be inadequate for your application.

Are there any other Building Code requirements?

Yes, there are various other requirements concerning framing, sheathing materials, sheathing paper, flashing, siding, shingling, and stucco application, etc. Most of these aspects of construction are dealt with in the previously mentioned book available from Canada Mortgage and Housing.

For Further Information

Planning & Building requirements may vary, depending on property lots.

We strongly encourage applicants to discuss their specific project with the City of Sarnia Planning and Building Department prior to commencement.



If you still require further clarification,
please contact Sarnia City Hall, Building Department.

CITY OF SARNIA
PLANNING & BUILDING DEPARTMENT

PO Box 3018, 255 North Christina Street
Sarnia, ON N7T 7N2



Phone: 519-332-0330

TTY: 519-332-2664

Fax: 519-332-0776

E-mail: buildept@sarnia.on.ca

www.sarnia.ca